

**Material / Material / Matériel / Material / Materiale**  
sanitaryacrylic

**Color / Colour / Couleur / Cor / Colore**

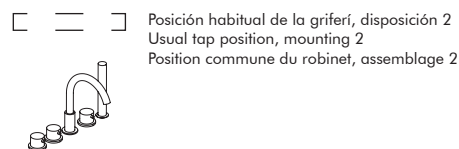
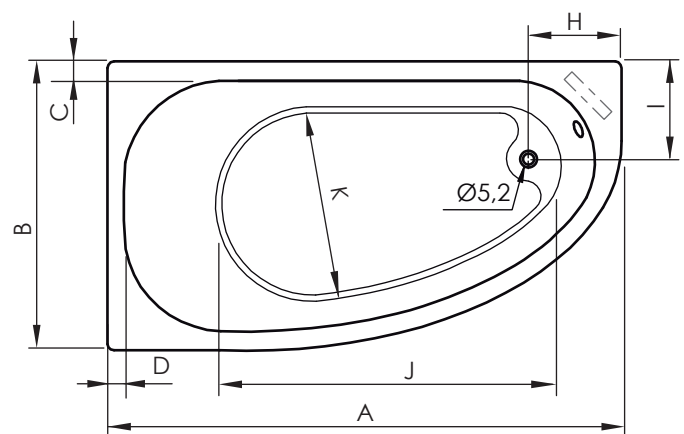
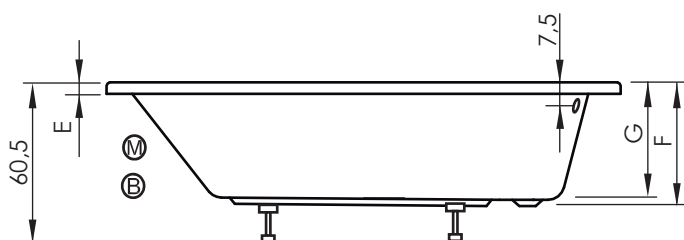
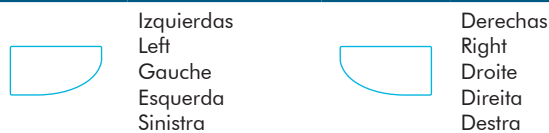

Posición habitual de la grifería, disposición 2  
Usual tap position, mounting 2  
Position commune du robinet, assemblage 2

cm  
+/- 0,5

dim.cm	A	B	C	D	E	F	G	H	I	J	K	P kg	P' kg	V cmxcmxcm	CA L	S m2	CS kg/m 2
160x90	160	90	60	50	3,5	39	37	29	30,5	109	61	21	25	170 x 95 x 44	175	1,78	104

**P:** Peso neto / Net weight / Poids net / Peso líquido / Peso netto

**P':** Peso de expedición / Expedition Weight / Poids d'expédition/ Peso do expedição / Peso spedizione

**V:** Volumen de expedición / Expedition Volume / Volume d'expédition / Volume do expedição / Volume spedizione

**CA:** Contenido agua / Water content / Contenu d'eau / Conteúdo de água / Contenuto acqua

**S:** Superficie cálculo / Calculation area / Calcul de surface / Cálculo de área / Area de calcolo

**CS:** Carga suelo / Floor load / Charge du sol / Cargo no solo / Carico di piano

**Preinstalación / Preinstallation / Pré-installation / Pré-instalação / Preinstalacion**

A pared / To wall / À mur / A muro / A parete

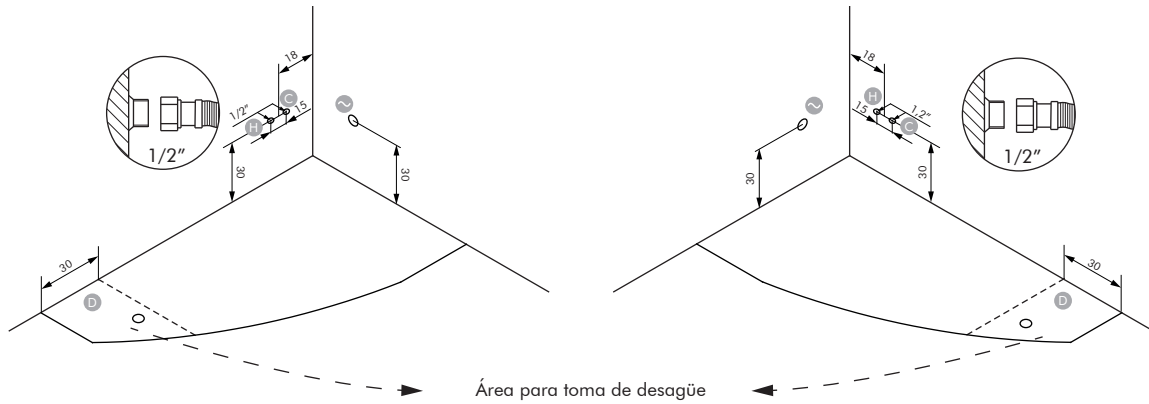

Encastre / Built-in / Encastrée / Encastré / Encastre

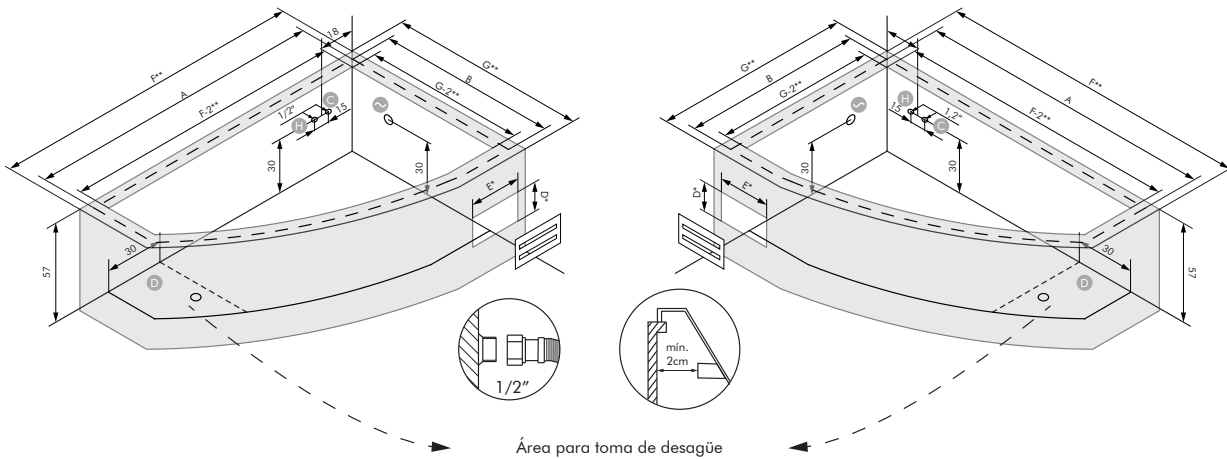

- M** Motor / Pump / Motore / Motor / Pompe
- B** Blower / Blower / Blower / Blower / Blower
- D** Desagüe / Waste / Bonde / Drenagem / Scarico
- C** Agua fría / Cold water / Eau froide / Água fria / Acqua fredda
- H** Agua caliente / Hot water / Eau chaude / Água quente / Acqua calda
- S** Toma corriente / Power outlet / Prise électrique / Tomada eléctrica / Presa di corrente

- \* Dimensiones óptimas para acceder a elementos eléctricos
- \* Optimal measures to access electrical components
- \* Dimensions optimales pour accéder aux éléments électriques
- \* Dimensões ótimas para acessar elementos elétricos
- \* Dimensioni ottimali per accedere agli elementi elettrici

- \*\* Dimensión a elegir por parte del cliente
- \*\* Dimension to be chosen by the client
- \*\* Dimension à choisir par le client
- \*\* Dimensão a ser escolhida pelo cliente
- \*\* Dimensione a scelta del cliente

COMPONENTES COMPONENTS / COMPOSANTS / COMPONENTES / COMPONENTI	EQUIPAMIENTO EQUIPMENT / ÉQUIPEMENT / EQUIPAMENTO / EQUIPAGGIAMENTO				
	Confort	T Confort	B Confort	DS Confort	Elegance
Motor hidro / Pump / Pompe hydro/ Bomba hidráulica / Pompa	●	●		●	●
Jets hidro / Jets hidro / Buses hydro/ Jatos hidro / Getto hidro	6	6		6	10
Blower / Blower / Blower / Blower / Blower			●	●	●
Jets blower / Jets blower / Buses blower / Jatos blower / Getto blower			10	10	10
Focos cromoterapia led / Led cromotherapy focus / Foyers chromothérapie led / Focos cromoterapia led / Foci cromoterapia led					●
Pulsador neumático / Pneumatic push / Commande pneumatique / Botão pneumático / Spinta pneumatica	●				
Regulador de aire / Air regulator / Variateur d'air manuel / Air regulador / Regulatore aria	●				
Pulsador on-off inox / On-off push inox / Commande on-off inox / Botão on-off inox / Spinta on-off inox					●
Boca de aspiración / Suction mouth / Bouche de succion / Boca de aspiração / Bocca di aspirazione	●	●		●	●
Panel táctil / Tactile panel / Panneau tactile / Pannel táctil / Pannello tactile		●	●	●	
Sensor de nivel / Sensor level / Détecteur de niveau / Sensor de nível / Sennsore di livello		●	●	●	●
Sistema autovaciado del blower / Self-emptying blower system / Système auto-vidange «blower» / Sistema auto-esvaziamento do blower / Sistema auto-svuotamento di blower			●	●	●
Peso kit / Kit weight / Poids kit / Peso kit / Peso kit (kg)	13	14	7,5	19	19
U (V)	230	230	230	230	230
F (Hz)	50	50	50	50	50
P (KW)	0,370	0,560	0,400	1,150	1,150
Nivel acústico / Acoustic level / Niveau sonore / Nivel de som / Livello sonoro (dB)	49	49	52	52	52

SH



B Confort



Confort



DS Confort



T Confort



Elegance



Izquierda / Left / Gauche / Esquerda / Sinistra

**Opcional / Optional / Optionel / Opcional / Opzionale**



BNACC171  
 Cromoterapia (6 leds RGB, pulsador inox)  
 Cromotherapy (6 leds RGB, stainless steel button)  
 Chromothérapie (6 leds RGB, bouton poussoir en inox)  
 Cromoterapia (6 leds RGB, botão de aço inoxidável)  
 Cromoterapia (6 leds RGB, pulsante acciaio inossidabile)



ACRYLMEC  
 Mecanizado para grifería especial, en bañera acrílica  
 Holes for special faucet, in acrylic bathtub  
 Usinage pour robinets spéciaux, baignoire acrylique  
 Usinagem de torneiras especiais, banheira de acrílico  
 Lavorazioni per rubinetti speciali, vasca in acrilico



**sanygrip**

BNACC171  
 Tratamiento antideslizante  
 Anti-slip treatment  
 Traitement antidérapa  
 Tratamento deslizamento  
 Trattamento antiscivolo

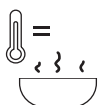

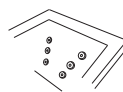

BNACC189  
 Calefactor (solamente para bañeras con equipamiento hidro)  
 Heater (only for whirlpool bathtubs)  
 Réchauffeur (tseulement avec équipement hydro)  
 Aquecedor (apenas para banheiras com equipamentos hidro)  
 Iscaldatore (solo per vasca con apparecchiature idro)



BNACC184  
 6 microjets lumbares  
 6 lumbar microjets  
 6 microjets lombaires  
 6 microjets lumbares  
 6 microjets lumbari

**Accesorios / Accesories / Accesories / Acessórios / Accessori**

<b>Faldón                      Panel                      Tablier                      Painéis                      Pannelli</b>	dim. cm	Acrílico Acrylic Acrilique Acrílico Acrilico	Ref.:	H cm
	160x90		FAL108	57

**Accesorios / Accesories / Accesories / Acessórios / Accessori**



BNACC159  
Grifería freestanding Nira  
Nira freestanding tap  
Robinet sur pied Nira  
Torneira freestanding Nira  
Rubinetto centrostanza Nira



BNACC188  
Grifería repisa Kali  
Kali over rim tap  
Robinet sur plage Kali  
Torneira prateleira kali  
Rubinetto mensola kali



BNACC195  
Grifería repisa Sky + desagüe con llenado  
Sky over rim tap + waste with filling  
Robinet sur plage Sky + bonde avec remplissage par trop plein  
Torneira prateleira Sky + sifão  
Rubinetto mensola Sky



BNACC165  
Asas (2 unidades)  
Handles (2 units)  
Poignés (2 unités)  
Asas (2 unidades)  
Maniglie ( 2 unità)



BNACC163N  
Reposacabezas CN3  
Headrest CN3  
Repose-tête CN3  
Encoste de cabeça CN3  
Poggiatesta CN3



BNACC164  
Reposacabezas CN4  
Headrest CN4  
Repose-tête CN4  
Encoste de cabeça CN4  
Poggiatesta CN4



BNACC170R  
Desagüe  
Waste  
Bonde  
Drenagem  
Scarico



BNACC187  
Desagüe con llenado  
Waste with filling  
Bonde avec remplissage  
Drenagem com preenchido  
Scarico con riempimento



BNACC166  
Perfil ABS (4m, fittings, recortable, instalación con silicona)  
ABS profile (4m, fittings, cut to fit, installation with silicone)  
Profil ABS (4m, fittings, recoupable, installation avec silicone)  
Perfil ABS (4m, fittings, recortáveis, instalação com silicone)  
Profilo ABS (4m, fittings, ritagliare, installazione con silicone)

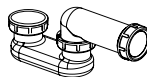

BNACC194  
Sifón bañeras  
Bathtub siphon  
Siphon pour baignoires  
Sifão banheiras  
Sifone vasca